

## FORME CLT3 3" LED CYLINDER FLUSH MOUNT - INSTALLATION INSTRUCTIONS

**READ AND FOLLOW ALL SAFETY INSTRUCTIONS!  
SAVE THESE INSTRUCTIONS AND DELIVER TO OWNER AFTER INSTALLATION.**

### WARNING: RISK OF ELECTRIC SHOCK

- Before installation or servicing DISCONNECT POWER BY SHUTTING OFF THE CIRCUIT breakers both to the outlet box and to its associated wall switch.
- Installation and service of luminaires should be performed by a qualified licensed electrician in accordance with all local and National Electrical Codes.
- Do not install damaged product.
- Verify that supply voltage is correct by comparing it with the luminaire label information.
- All wiring connections should be capped with UL approved wire connectors.

### WARNING: RISK OF INJURY

- Allow luminaire to cool before servicing.
- Follow all manufacturer's warning and restrictions for driver type, mounting locations, replacement and recycling.
- Wear safety glasses and gloves when installing, maintaining or servicing.
- Avoid direct eye exposure to the light source while it is on.

### WARNING: RISK OF FIRE

- Do not separate any wires that may be in the box.
- Do not damage the insulation of existing wiring.
- In regular circumstances the BLACK wire will be the "Hot" lead and the WHITE wire will be the "Neutral" or "Common" lead. A GREEN or BARE COPPER wire is the "Ground." In older buildings, it is always good practice to reconfirm the polarity of the wiring.

### RISK OF PRODUCT DAMAGE

- Never connect components under load.
- Do not touch the yellow surface of the LED as it may damage the light engine.

### TOOLS REQUIRED



Size #2 Phillips  
Screw Driver

### ACCESSORIES REQUIRED

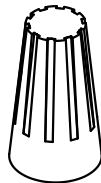

Electrical Wire Nut

## FORME CLT3 3" LED CYLINDER FLUSH MOUNT - INSTALLATION INSTRUCTIONS

### STEP 1 | INSTALLATION

#### Attach Mounting Plate & Make Electrical Connections

- Connect supply wires using approved wire nuts to the cylinder using the wiring diagram shown.
- Using a #2 Phillips screwdriver fasten mounting plate to junction box.
- Attach canopy over mounting plate.

1

NEUTRAL (WHITE)  
LINE (HOT) - (BLACK)  
GROUND (GREEN)

Optional for 0-10V Dimming  
+ DIM (PURPLE)  
- DIM (PINK)

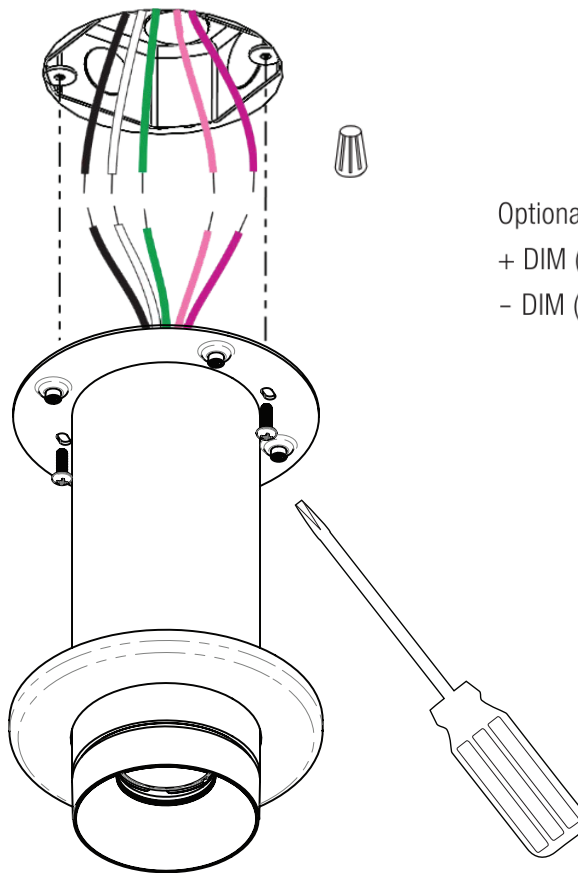

**⚠ WARNING**

MAKE SURE THAT THERE ARE NO EXPOSED STRANDS OF WIRE THAT COULD CAUSE A DANGEROUS SHORT CIRCUIT!

**⚠ WARNING**

NEVER FASTEN THE GROUND WIRE (GREEN) TO THE HOT (BLACK) WIRE!  
FAILURE TO FOLLOW THIS INSTRUCTION COULD RESULT IN SERIOUS INJURY OR DEATH!

## FORME CLT3 3" LED CYLINDER FLUSH MOUNT - INSTALLATION INSTRUCTIONS

### WIRING DIAGRAMS

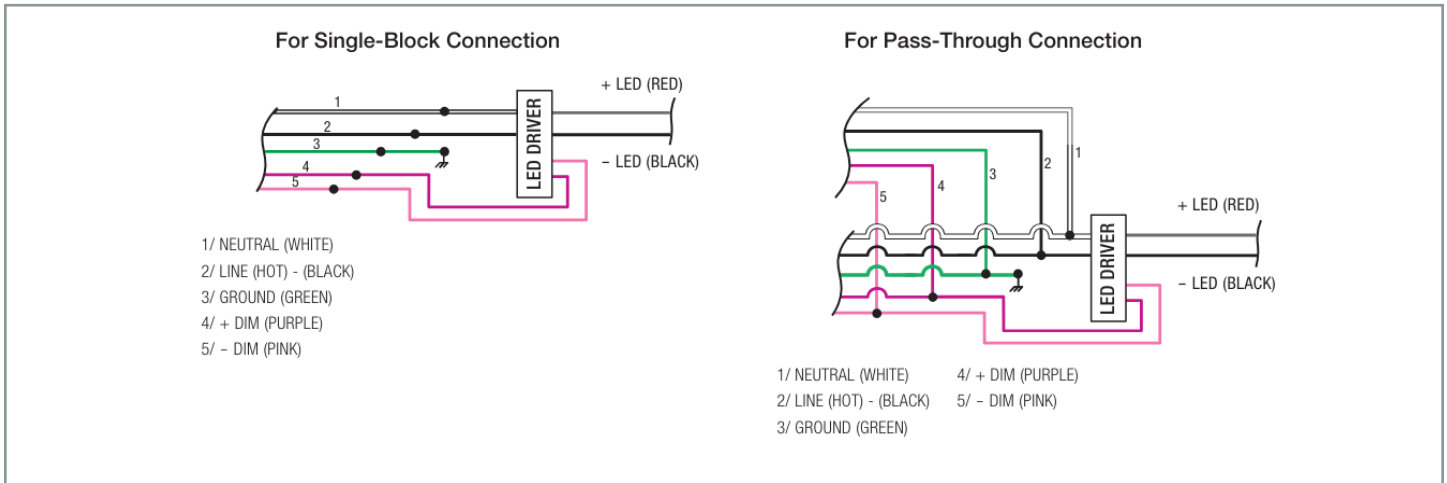

### REMOVING/INSTALLING OPTICS OR MEDIA

- Remove the Bezel by pulling it from the housing.
- Remove optic by rotating it counter-clockwise.
- If attaching media, remove Media Holder, place Media(s) and reattach Media Holder to Optic.
- If installing Optic, with desired Optic reverse the previous steps.

